



3:rock
CREATE : MANUFACTURE : DELIVER

Where
ideas
become
landmarks

Full-scale signage design,
fabrication & installation.

BIG VISIONS BIGGER SIGNAGE.

For over two decades, **3:rock** has delivered bold, high-impact signage that transforms brands into landmarks.

We combine creative thinking, technical precision, and full in-house manufacturing to bring ideas to life at any scale.

From the first spark of an idea to the final bolt on site, we manage every stage of the journey - delivering signage that performs, inspires, and endures.

80+

years of industry
experience

76K+

projects completed
to date

60+

dedicated
team members

THE COMPLETE SIGNAGE JOURNEY

1

CREATE

From initial consultation to concept development, our creative and technical teams work together to interpret your brand and vision.

We explore ideas, visuals, materials, and structural possibilities – ensuring every design is functional, feasible, and unmistakably you.

2

MANUFACTURE

Inside our state-of-the-art production facility, concepts are transformed into precision-built structures.

Our skilled fabricators, engineers, and technicians use advanced machinery and premium materials to ensure exceptional quality, durability, and finish.

3

DELIVER

Our certified installation teams ensure every sign is safely and flawlessly installed.

We coordinate logistics, site access, and compliance – delivering a smooth, efficient process with minimal disruption.

CAPABILITIES & TECHNOLOGY

Our in-house capabilities give us complete control over quality, timelines, and creative outcomes.

Whether it's a single architectural feature or an entire nationwide rollout, we're equipped to deliver at scale - with precision, reliability, and a commitment to excellence.

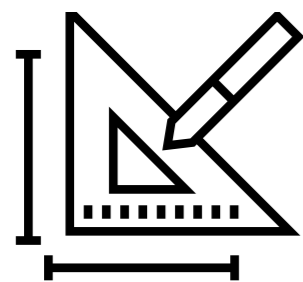

DESIGN & ENGINEERING

Concept development, 3D modeling, prototyping, technical drawings, planning & compliance.



FABRICATION & PRODUCTION

Metal fabrication, CNC machining, welding, illumination systems, large-format printing, finishing, coatings.

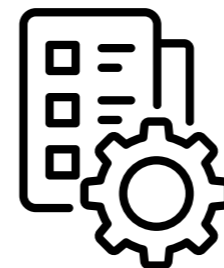

PROJECT MANAGEMENT

Dedicated project leads ensure seamless communication, structured timelines, and efficient co-ordination from start to finish.



QUALITY & COMPLIANCE

Certified installation teams, industry-approved materials, and robust safety processes underpin every project.

DESIGN THAT DEFINES SPACES

We believe **great signage** is more than a marker – it's an **experience**. Our designers **push creative and structural boundaries**, developing concepts that combine aesthetics, functionality, and engineering intelligence.

From early sketch explorations to detailed 3D renders, we visualise every detail before production begins. This ensures clarity, accuracy, and the freedom to experiment with materials, form and lighting.

PRIMARK

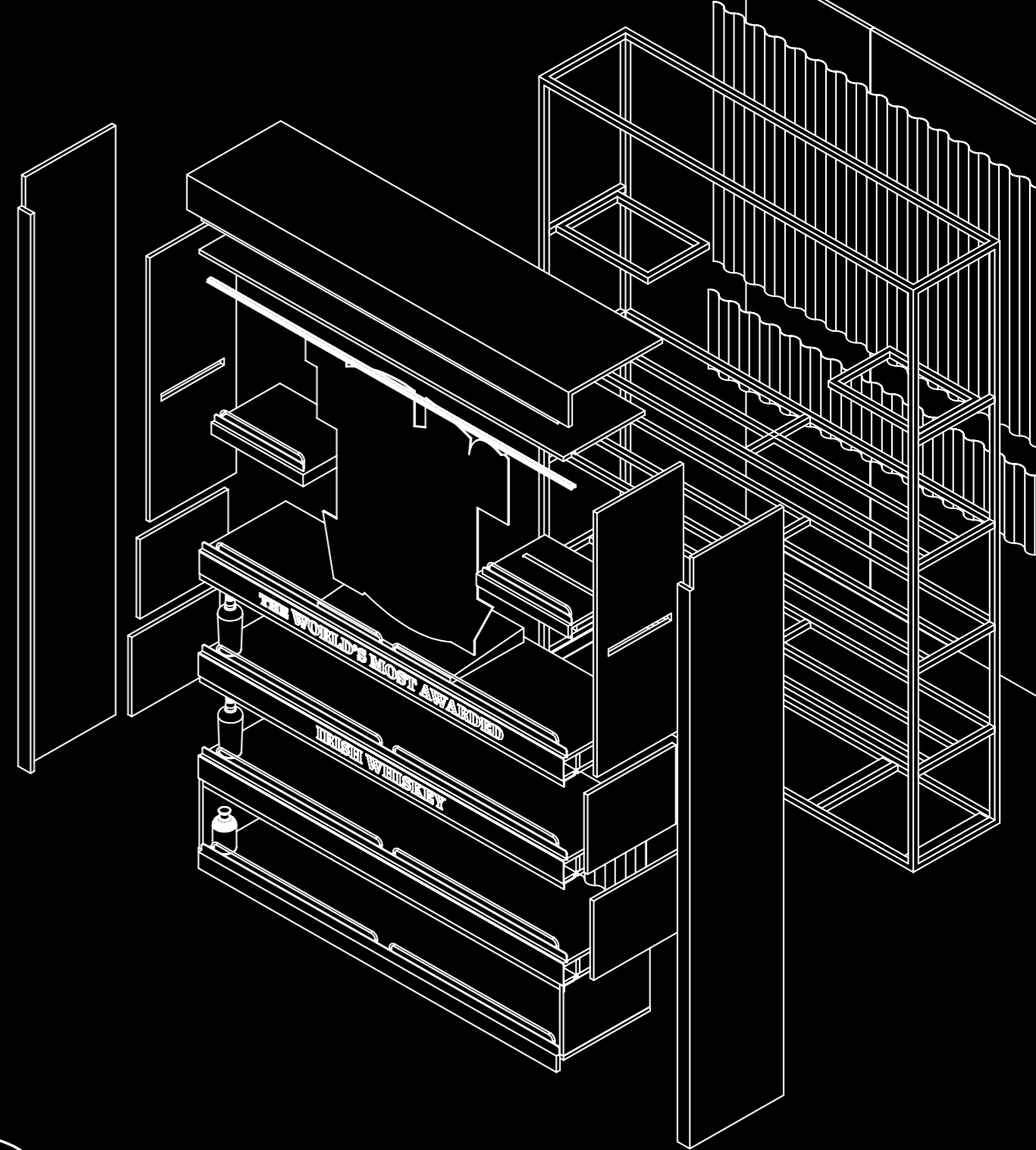



SuperValu

SuperValu brand collection highlights **3:rock**'s full end-to-end capability across design, engineering, fabrication, and installation. From large-scale illuminated lettering to bespoke suspended structures and distinctive feature lighting, each project demonstrates our ability to turn concepts into precision-built, visually impactful solutions. These case studies showcase the craftsmanship, innovation, and technical expertise that define our work across premium retail environments.

IN PARTNERSHIP WITH

Musgrave

KANE
GROUP





SUPERVALU HANSFIELD

BUILT-UP ILLUMINATED LETTERS

We manufactured a full suite of front- and back-lit built-up LED letters using our in-house assembly lines. With complete control of the production chain, we delivered large-scale, custom lettering- up to 3 metres high and over 400 characters per project. Our integrated design and engineering teams handled concept development, technical design, fabrication, and installation.

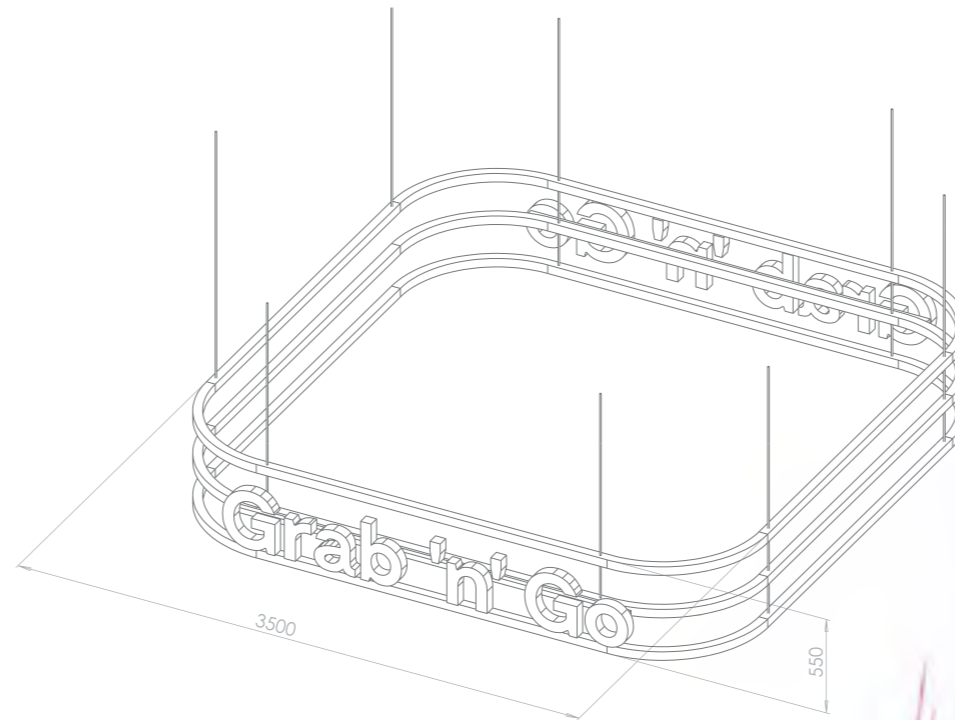

SUSPENDED METAL CAGE SIGNAGE

Using our 15,000 sq ft metal fabrication facility, we produced bespoke suspended box-section signage for SuperValu Hansfield. From early concept visuals to engineered technical drawings, we developed and fabricated three-tier curved aluminium structures designed to frame key retail zones. Each unit was precision-rolled, assembled, and installed as a standout ceiling feature.

SUPERVALU CLONAKILTY

DOUGHNUT HANGING LIGHT FEATURE

For SuperValu Scally's Clonakilty, we created a playful suspended illuminated feature inspired by a modern bakery aesthetic. The installation includes ring-shaped "doughnut" elements in pastel tones, two concentric LED-lit aluminium/acrylic bands, and built-up illuminated DOUGHNUTS lettering - fully integrated with concealed wiring for a clean, floating effect.

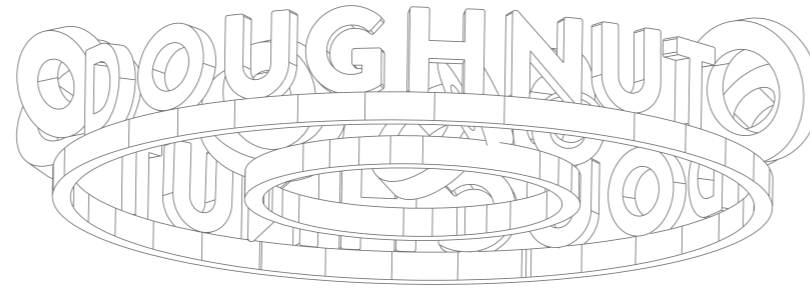

THE SOUK FEATURE

Our team designed and supplied the mechanical components for the suspended acrylic panels, folded aluminium fascia, illuminated lettering, and patterned vinyl for the Souk area at SuperValu Scally's. All elements were engineered for seamless suspension, durability, and visual impact.

Centra

Every Centra store showcases **3:rock**'s commitment to transforming design ideas into standout experiences. Through custom lighting, feature installations, and tailored interiors, each space is crafted to reflect the brand's personality while engaging shoppers. These projects highlight the thoughtful design and technical expertise that define our approach to premium retail.



CENTRA CUSTOM BRANDS

Our Design Studio is dedicated to bringing every store's unique identity to life. We understand that no two communities are the same - and your store's brand should reflect the people, personality, and purpose behind it.

Let our design team partner with you to develop your brand.



CENTRA DRUMCONDRA

ELEVATED ILLUMINATED FIXTURE

Working with Domus on this unique circular section header, we delivered high-quality application by adapting built-up illuminated lettering to a curved rail. This highlights that customisation is limitless, creating products to suit your parameters and allowing projects to step into new realms that impress.



CENTRA CASTLETYMON

STORE OF
2025
THE YEAR





Approved as one of only two signage and shopfit suppliers at Dublin Airport, fully badged for airside access, and trusted to deliver high-quality solutions for over seven years.

We deliver both internal and external projects, from large lightboxes and bespoke illuminated lettering to shop fit-outs, duty-free displays, and high-impact print installations, coordinating all parties and contractors on-site from concept to final installation.



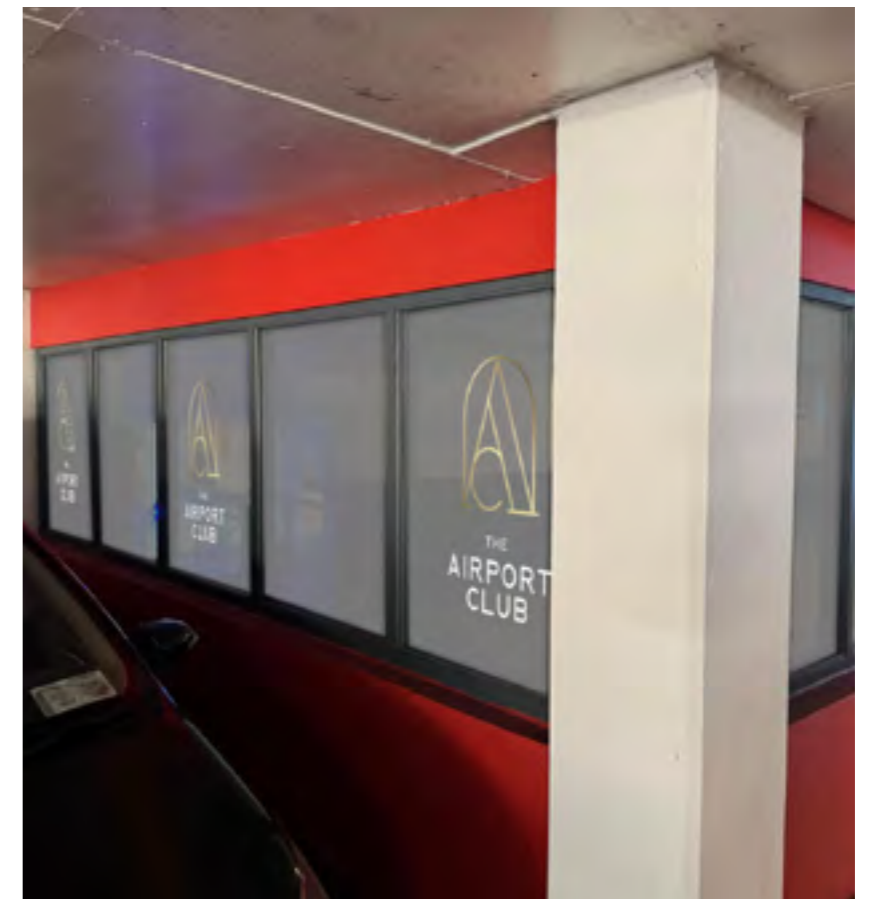
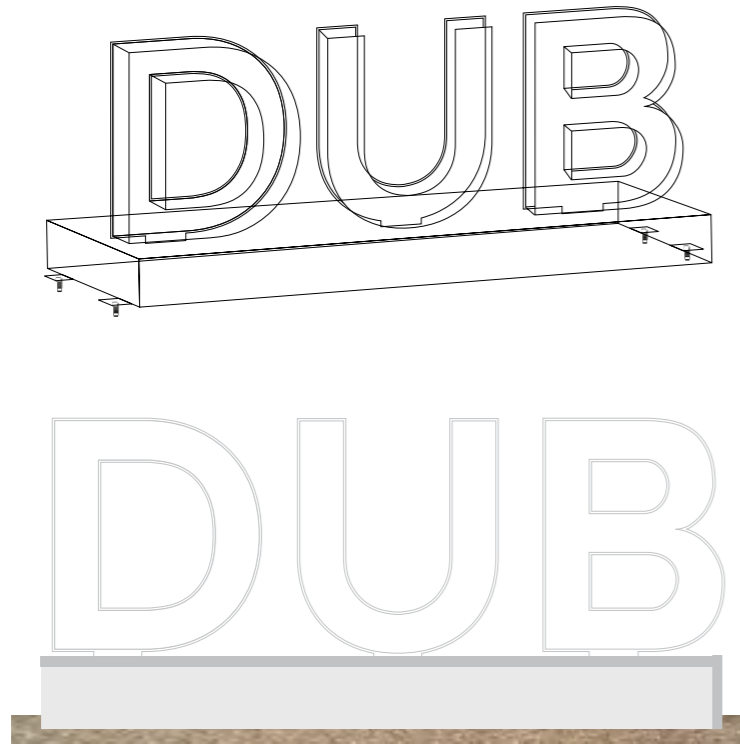

TEELING

REBORN 2012



WHISKEY

We transformed concepts supplied by the design company's, into production drawings and thereon into bespoke fabrication and joinery displays. Working in close partnership with an external design team, we delivered a complete customer journey with displays including branded barrels and illuminated counters.



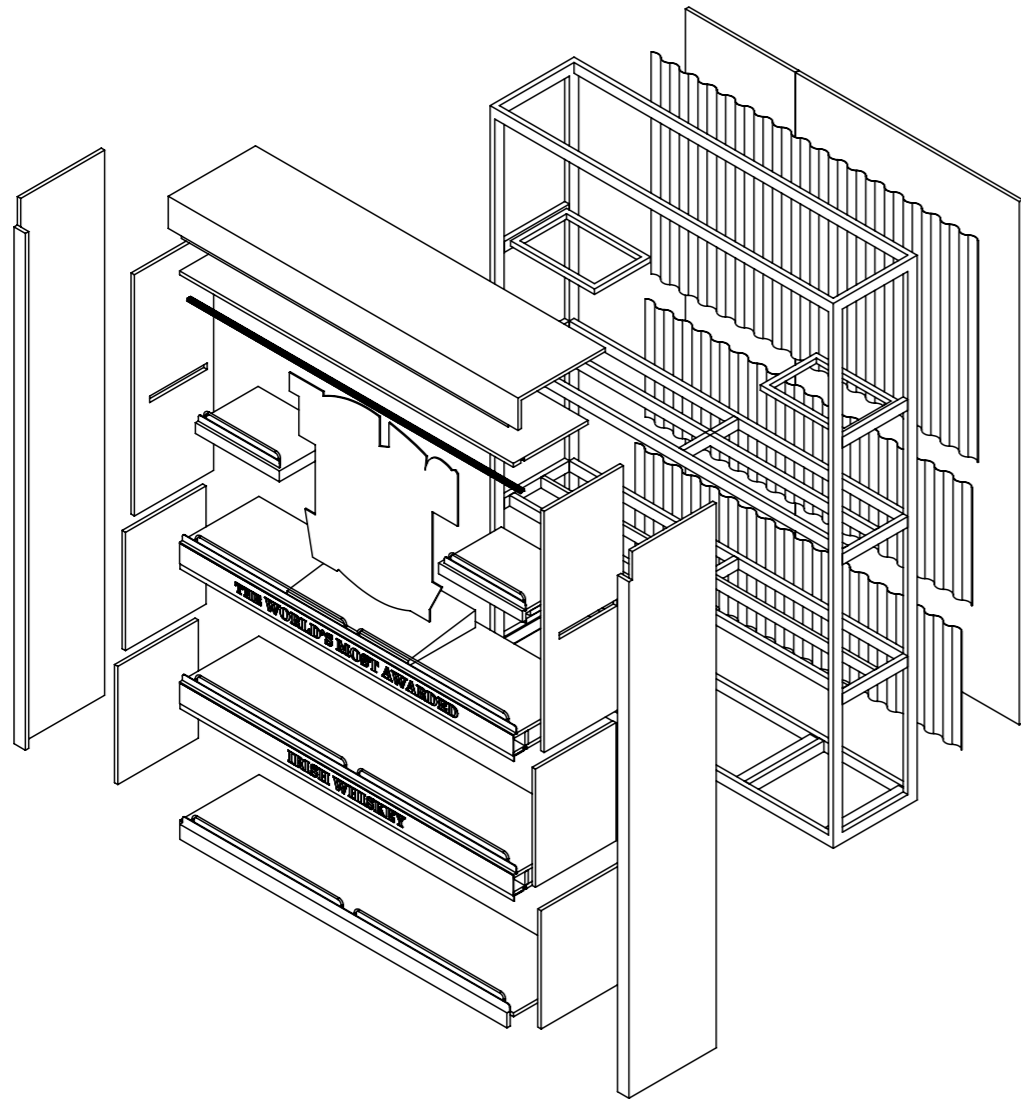

**BELFAST AND DUBLIN AIRPORT
DISPLAY CASE**

Designed, Manufactured and Installed
by **3:rock**



SHOP FIT-OUT & SIGNAGE FOR JUMP JUICE BARS

Jump Juice are the positive option in healthy choices for the active person on the go. They serve up a selection of the best tasting fresh juices and smoothies in a fun environment that will leave you wanting more.

Working closely with the Rigney Forge who design each store we then specialise in delivering high-end shop fit-outs and bespoke signage for Jump Juice Bars across Ireland. From in house fabrication through to installation, every detail is carefully managed to ensure brand consistency, quality finishes, and a seamless customer experience.





Our expertise covers interior fit-outs, external fascias, illuminated signage, and internal branding, all crafted to the highest standards. The result is a refined, vibrant space that brings the Jump Juice brand to life—efficiently, reliably, and with lasting impact.



Lilian's

We delivered a full cafe and bar installation at Dublin Airport as part of a major food and beverage transformation project operated by KSG. Our work included illuminated signage, custom counters, and cafe barriers, transforming the design concept into a fully realised, functional, and visually engaging space. This project showcased our ability to combine technical expertise with precision fabrication to bring complex retail environments to life.







As the approved signage supplier for Costcutter, **3:rock** specialises in the design, manufacture, and nationwide installation of high-quality signage across all stores. From factory to storefront, we deliver premium signage on time and on brand, combining technical precision with creative execution. This long-standing partnership highlights our ability to manage large-scale retail signage projects while maintaining consistent brand standards nationwide.



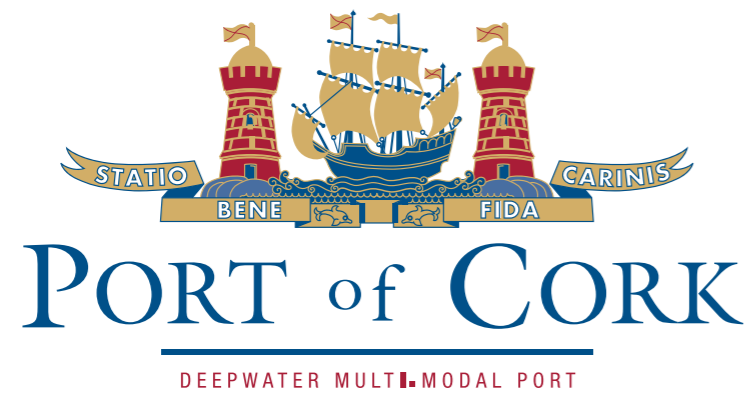

3:rock in collaboration with a design agency, engineered and manufactured a set of super-sized signs for two cranes operating in the Ringaskiddy terminal in the Port of Cork. Installing $\frac{3}{4}$ of a tonne built-up illuminated angled letters "MAHAIN & BINNE" which sit 85 ft up on the 50m on the x-axis of the Liebherr cranes.



LIEBHERR
- UNDER TWIN LIFT TELESCOPIC SPREADER
- SINGLE LIFT MODE - 40 Tonnes
- UNDER HOOK BEAM - 47 Tonnes
- MANUFACTURED 2020

3:rock

3:rock

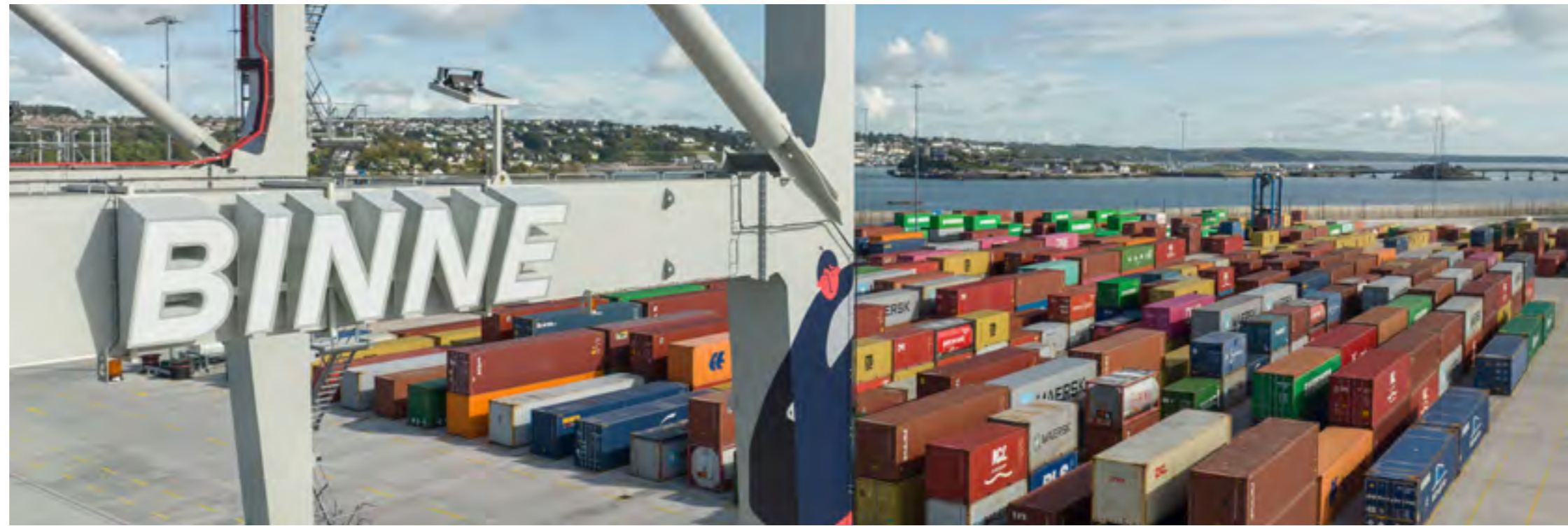

Our product development team faced a unique challenge here, in designing the fixing mechanism to brace the lettering to the crane. Working with Liebherr we ensured the framework did not compromise the crane structure and specialised galvanized clamp structure at 8m long was developed, allowing **3:rock** to never directly drill into the steel of the frame.

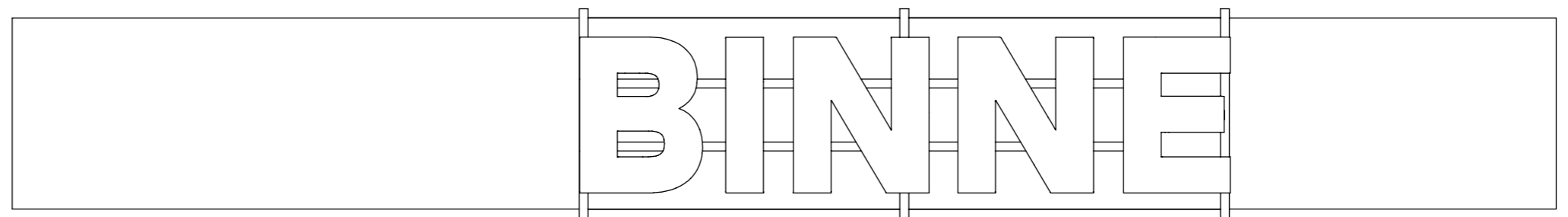
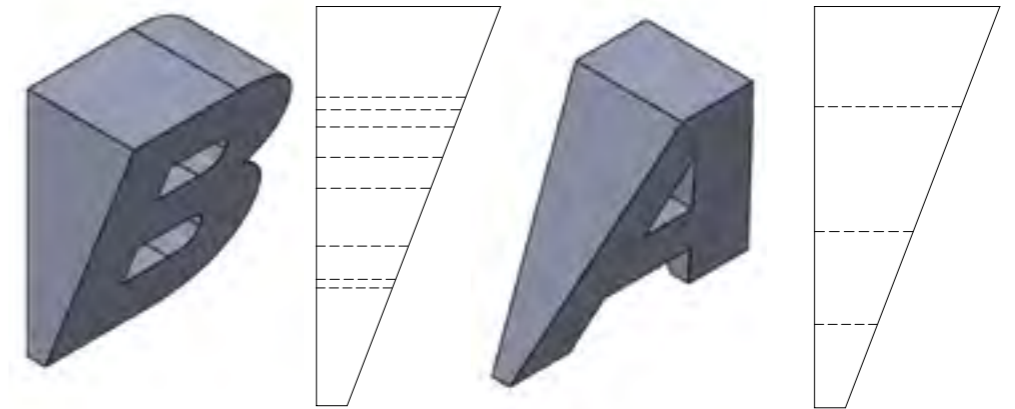

UPMC

LIFE CHANGING MEDICINE

Hurling is an establishment in Kilkenny, and Nowlan Park is the home to this. Kilkenny Hurling's new partnership with UPMC required new striking signage along the stadium exterior, and we were tasked with delivering this project.

The sheer scale of this sign made it a challenge to both fabricate and install. In addition, the finished sign had to fix onto the existing grounds, and there was no margin for error.

Our designers, fabricators and installers all worked collaboratively to create a solution that would work. Detailed site surveys were essential to the design process, and our expert installation crew ensured every element was covered.

The visibility of Nowlan Park on the Kilkenny skyline has been drastically increased, including at night when the built-up letters are illuminated. In addition, the partnership between Kilkenny Hurling and UPMC has been made prominent thanks to this new signage.





CROKE PARK

Arguably one of the most iconic signs in Ireland, **3:rock** were given the responsibility of refurbishing the entrance sign to Croke Park, the home of GAA. A high level of skill and specialised manufacturing techniques were needed for this project!

Within a short window of two weeks, our in-house experts had to be on hand to uninstall, refurbish and re-install this iconic sign. The sign is textured and embossed to give it a 3-dimensional look. Our fabrication team used a mix of a steel structure, fibre-glass, and a specialised gel coat paint finish matched to the original GAA brand colours.

Once the sign was refurbished in our workshop, our installation team co-ordinated with the GAA to find a window of time that worked for local residents and events in Croke Park. Installed just before Ed Sheeran's arrival and the start of the 2022 championship, a seamless installation was achieved successfully thanks to our expert crew.

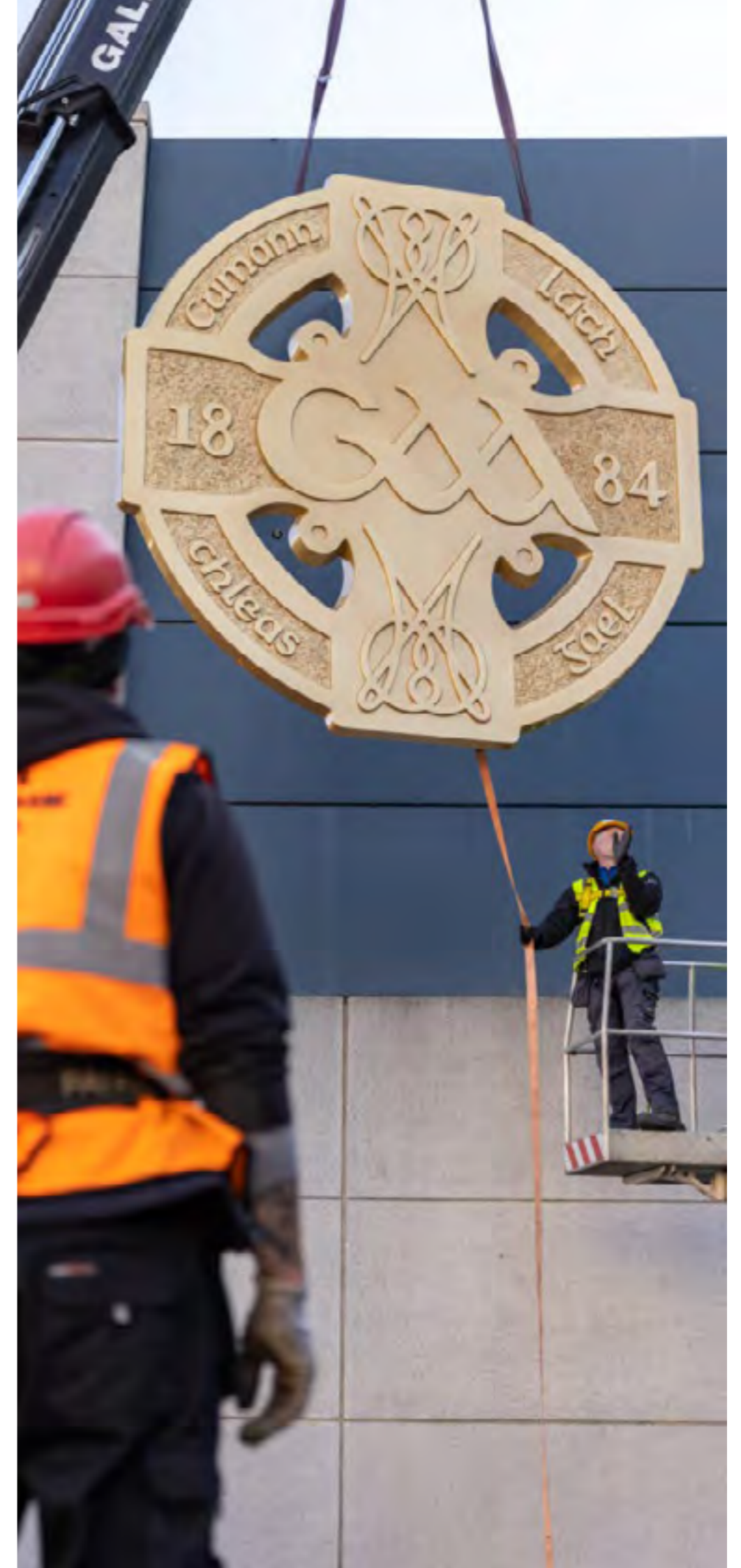

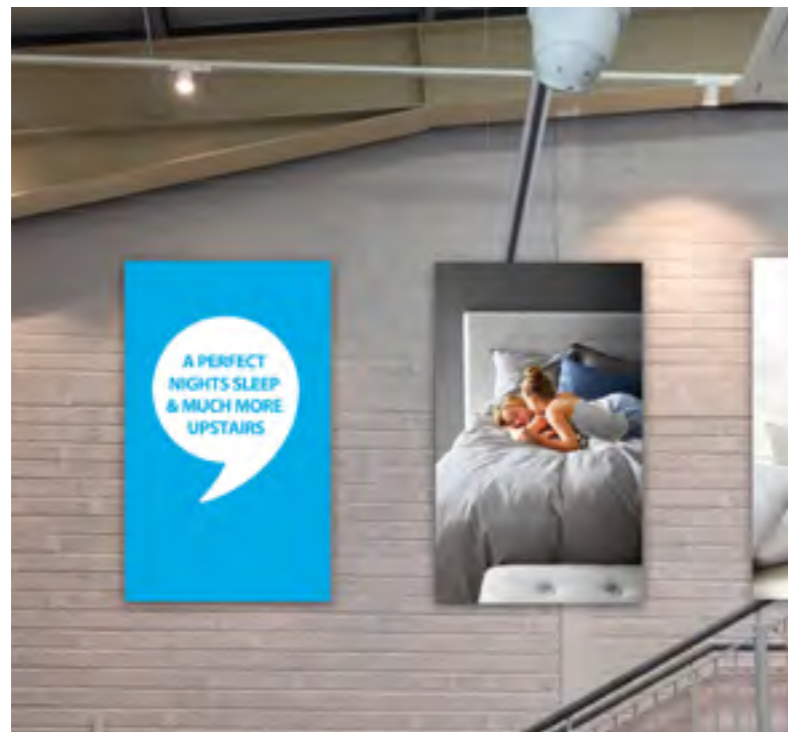

Our Graphic Design and Metal Fabrication departments worked closely to produce all of the exterior and interior signage for JYSK's new stores. The entire production and installation were handled in house by our skilled teams.

From the main large exterior fascia sign right and window graphics right to down the interior posters, **3:rock** produced a suite of signage and POS materials with consistency and top quality craftsmanship.

Our process involves a high degree of communication and input from each department to produce the level of precision expected by our client. Every department works in unison towards the same goal of flawless production and installation.



3:rock have a long-standing relationship with Circle K, who complete revamps on a weekly fit out turnaround timeframe. **3:rock**'s scale enables us to keep up manufacture and maneuver to the evolving requirements of the large multinational franchise.

The genius of the interior signage fit out of a Circle K, is the clever use of vinyl. The store fitting timber finish's throughout are actually different vinyl finish's installed by **3:rock** onsite.



KEF KEFLAVÍK AIRPORT

Tasked with two displays for a new Duty Free area by Mars and HHI Global in Keflavík Airport, we developed the proposal into detailed designs and CAD drawings. Once approved, we manufactured the displays and shipped them to Iceland, where our experienced crews completed installation in just two days, delivering a fully operational, high-quality result on time and to specification. This project highlights our capability to manage complex international installations with precision and efficiency.

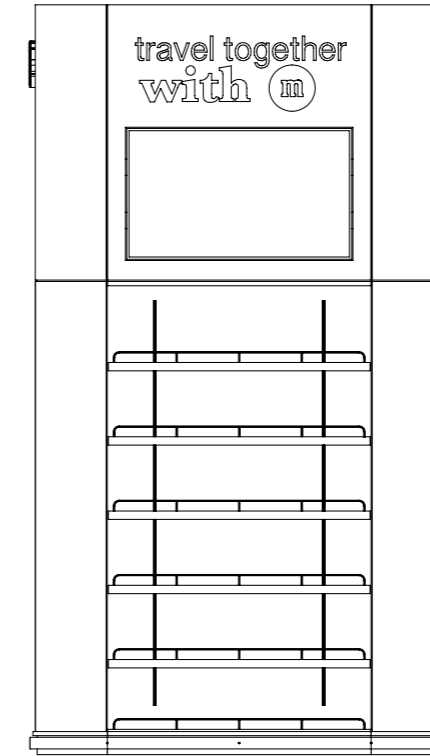

PRIMARK

3:rock is a trusted signage partner to Primark, appointed as their listed signage contractor for the Republic of Ireland and one of just three approved signage partners across continental Europe. Recent Irish Primark fit-outs delivered by **3:rock** include Bray, O'Connell Street and Fountain House, Belfast, alongside international projects such as Caen Mondeville in France and Biella in Italy.

Due to the scale and complexity of Primark stores, the signage scope on each fit-out is both extensive and technically demanding.

Every element; from design, manufacture and installation; is required to meet Primark's exacting standards and is delivered strictly in line with their detailed technical specification manual.



All manufacturing and installation details are closely monitored, with zero tolerance for deviation from approved construction specifications. To guarantee consistency, **3:rock** operates strict internal quality control procedures, with all goods fully checked and formally signed off by QC prior to dispatch. Quality is embedded at every stage.

Store revamps are typically carried out within live trading environments. To minimise disruption to customers, signage installation is primarily completed outside of trading hours. Larger signage packages can involve up to thirty consecutive nights of on-site installation, overseen throughout by a dedicated **3:rock** site supervisor.

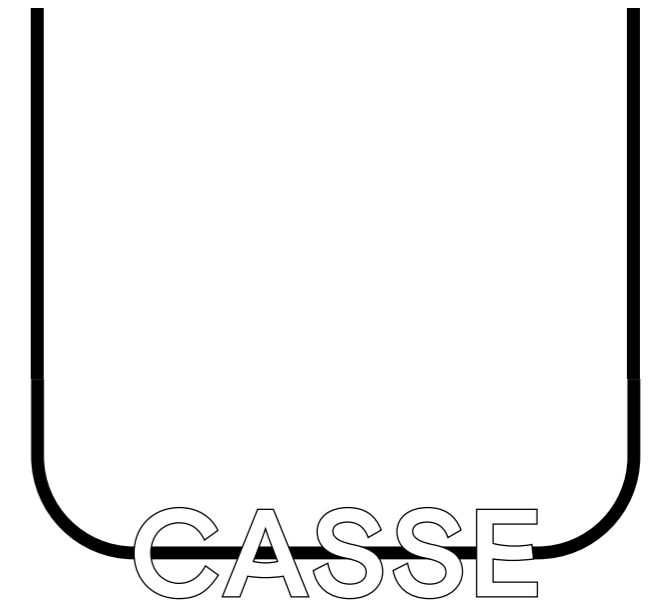

Our site supervisor reports directly to the **3:rock** account manager and works closely with the main contractor to ensure programme certainty, quality delivery and site safety. All fixing methods meet rigorous safety standards, with pull testing carried out, recorded and submitted to Primark, providing full confidence in the longevity and performance of every installation.

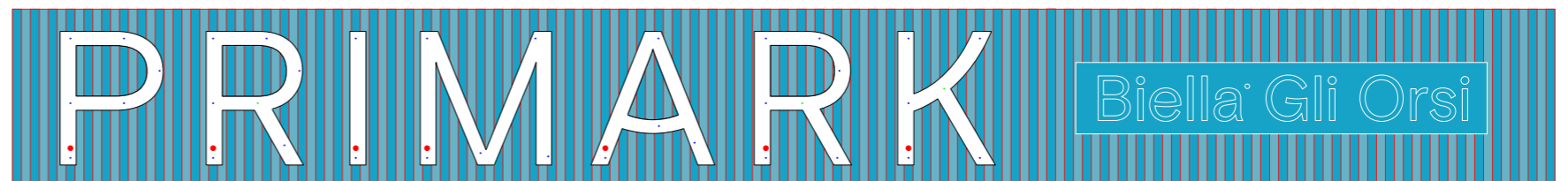
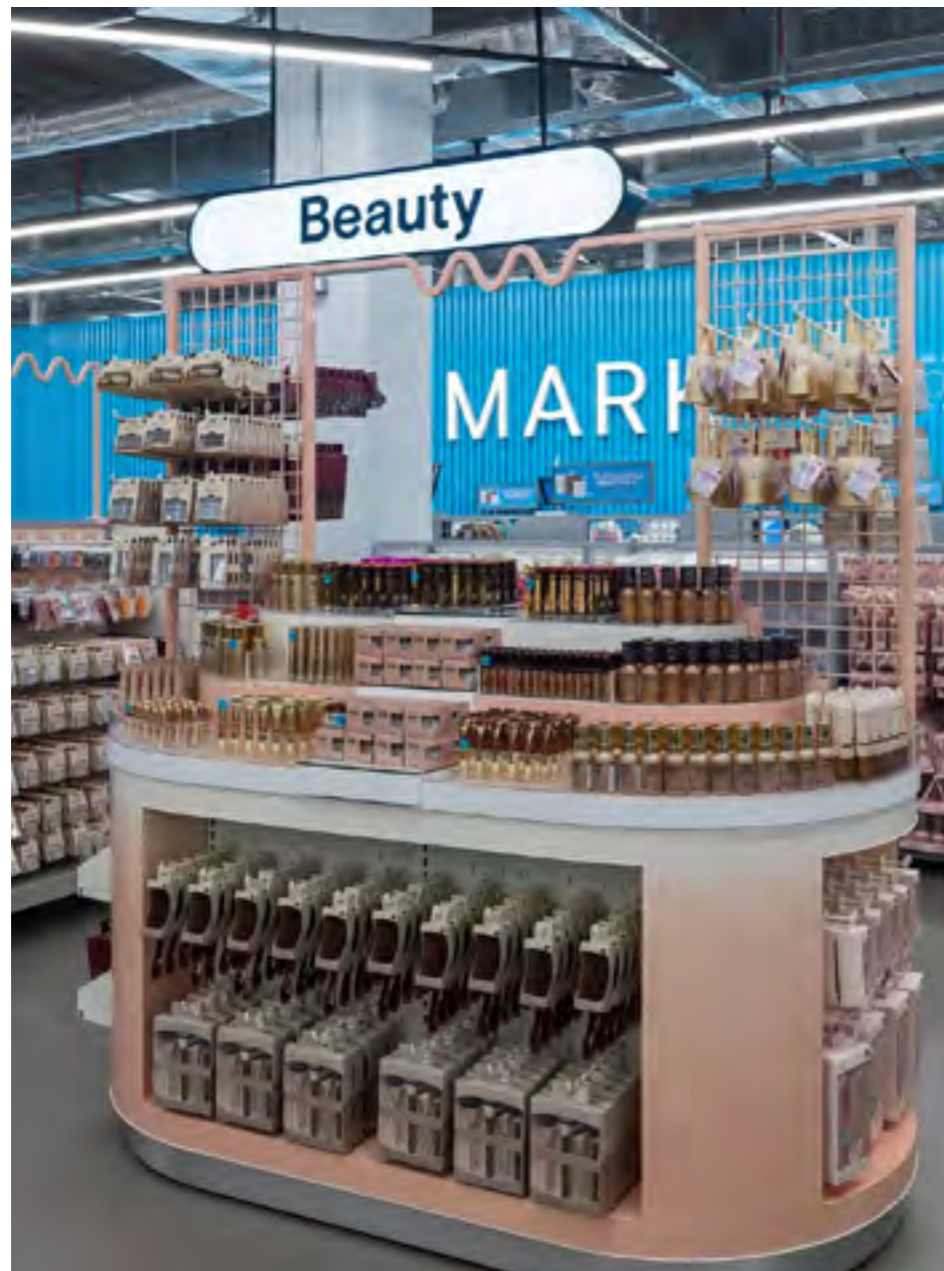

TRUSTED BY BIG BRANDS.

Our work spans multinational corporations, national retailers, hospitality leaders, government bodies, and major large-scale developments. Over the years, we've partnered with organisations across a wide range of sectors, supporting them through complex challenges and high-visibility projects. We're proud to have built long-standing relationships grounded in trust, consistency, and measurable results.

By combining deep industry insight with a commitment to quality and collaboration, we continue to deliver solutions that not only meet expectations but elevate our clients' brands and long-term objectives.





Let's Build Something Unmissable

**Ready to bring your
vision to life?**

Speak to our team about your next
signage project – big or small.

Reach out:

Sean O'Reilly

Commercial Director

E: sean@3rock.ie

M: +353 (0) 87 774 9620

T: +353 (1) 457 0188

W: www.3rock.ie



Unit 7/8 Crag Avenue,
Clondalkin Ind. Estate,
Clondalkin,
Dublin 22

